



CFA Society of Madison & Milwaukee

November 30, 2016



VEHICLE ACCESS SYSTEMS TECHNOLOGY



WITTE • STRATTEC • ADAC

Patrick J. Hansen

Senior Vice President & CFO

Disclosure for Presentation at CFA Society of Madison and Milwaukee

This presentation contains “forward-looking statements” within the meaning of the Private Securities Litigation Reform Act of 1995. These statements may include expected future financial results, product offerings, global expansion, liquidity needs, financing ability, planned capital expenditures, management’s or the Company’s expectations and beliefs, and similar matters. The Company’s business, operations and financial performance are subject to certain risks and uncertainties, which could result in material differences in actual results from the Company’s current expectations. These risks and uncertainties include, but are not limited to, general economic conditions, in particular, relating to the automotive industry, customer demand for the Company’s and its customer’s products, competitive and technological developments, customer purchasing actions, foreign currency fluctuations and costs of operations. Such risks and uncertainties are discussed further in the Company’s filings with the Securities and Exchange Commission.

This presentation includes selected information regarding the Company’s business, operations and financial performance and is qualified in its entirety by the more complete information contained in the Company’s filings with the Securities and Exchange Commission and other public disclosures.

All information in this presentation is as of November 30, 2016 and any distribution of this presentation after that date is not intended and will not be construed as updating or confirming such information. The company undertakes no obligation to update any information in this presentation to reflect subsequent events or circumstances.

This presentation can be found at:
www.strattec.com
Investor Relations
Presentations



- 1908 Briggs & Stratton Corporation formed
- February 27, 1995 Briggs & Stratton spins off their lock division as a separate publicly traded company named “STRATTEC SECURITY CORPORATION” (Symbol STRT traded on NASDAQ)
- November 28, 2000 Alliance and joint venture formed between STRATTEC and WITTE creating WITTE-STRATTEC LLC
- November, 2001 Joint venture is formed with Brazilian partner and WITTE-STRATTEC LLC to create WITTE-STRATTEC do Brasil
- March 1, 2002 Joint venture is formed with Taiwanese Company to form WITTE-STRATTEC China

- March, 2004
Second facility and legal entity is formed in Shanghai called WITTE-STRATTEC Great Shanghai
- July 1, 2006
ADAC Plastics Inc. – Grand Rapids, MI joins WITTE-STRATTEC LLC joint venture which is renamed Vehicle Access Systems Technology (VAST LLC). Other outside joint ventures are renamed VAST China and VAST do Brasil
- October, 2006
STRATTEC and ADAC create joint venture ADAC-STRATTEC de Mexico to produce door handle components in Juarez, Mexico
- August, 2007
VAST establishes sales office in Japan (VAST Japan)
- November 30, 2008
STRATTEC, WITTE and VAST acquire the global Delphi Power Products business. STRATTEC creates joint venture with WITTE called STRATTEC Power Access LLC for power sliding doors and lift gates. Sales & Engineering office is also created in Seoul Korea called VAST Korea to service primarily Hyundai/Kia and other OEM's.

- April 30, 2015 VAST LLC acquires 50% interest in an existing Indian Access Control Company owned by Spark Minda. New Joint Venture is named Minda VAST Access Systems (MVAS)

Milwaukee, WI - 420 Employees (330, 000 sq. ft.)
Headquarters, Engineering, Parts Manufacturing

Troy, Michigan - 70 Employees (65,000 sq. ft.)
Sales, Engineering, and Prototyping

Juarez, Mexico - 3,300 Employees (325,000 sq. ft.)
3 Facilities – Assembly, Key Finishing
& Plastic Injection Molding

El Paso, Texas - 50 Employees (110,000 sq. ft.)
Distribution

Leon, Mexico – Paint & Assembly Facility (135,000 sq. ft.)
Opening Early 2017

Product and Sales Information

2001

Keys & Locksets

- Mechanical keys
- Mechanical keys w/ electronic security enhancements
- Ignition locks
- Door locks
- Rear compartment locks
- Glove box locks
- Accessory locks

Driver Controls

- Steering column mounted ignition lock housings

Miscellaneous Industrial

- Zinc die-castings

2016

All the products in place in 2001, plus

Keys & Locksets

- Electro-mechanical entry keys w/remote entry electronics
- Bladeless electronic keys
- Electronic remote entry key fobs
- Codeable locks
- Biometric Locks

Driver Controls

- Instrument panel mounted ignition lock housings
- Instrument panel docking receivers for bladeless electronic keys
- Instrument panel "Push to Start" ignition switches for passive security systems

Latches

- Rear compartment (tailgate, liftgate, trunk lid)
- Seat Back

Power Access

- Power sliding side door systems
- Power liftgate
- Power trunk lid
- Power cinching latches & strikers
- Electronic control modules

Door Handles & Functional Exterior Trim

- Inside and outside handles
- Outside handle chassis
- Rear license plate light bars with park assist cameras and/or concealed switches for releasing rear compartment latches

Miscellaneous Industrial

- electronic vehicular access systems

Access Products Portfolio

- Locks & Keys
- Power Doors
- Handles
- Latches
- Steering Column Security
(Mechanical and Electronic)
- Fobs
- Push Button Start
- Aftermarket Products



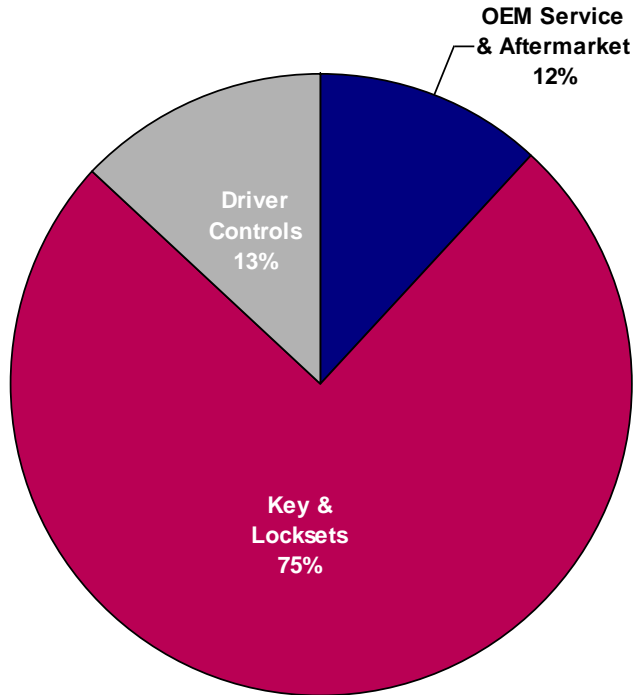

Fiscal Year 2001
Net Sales = \$203 million

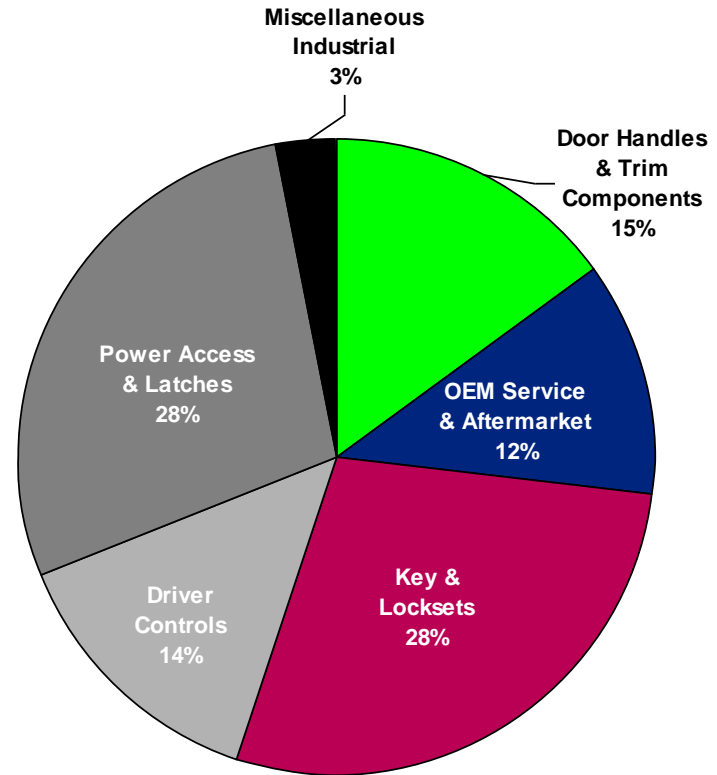

Fiscal Year 2016
Net Sales = \$401 million

NOTE: Page 58 in the 2016 Annual Report

Sales by Customer

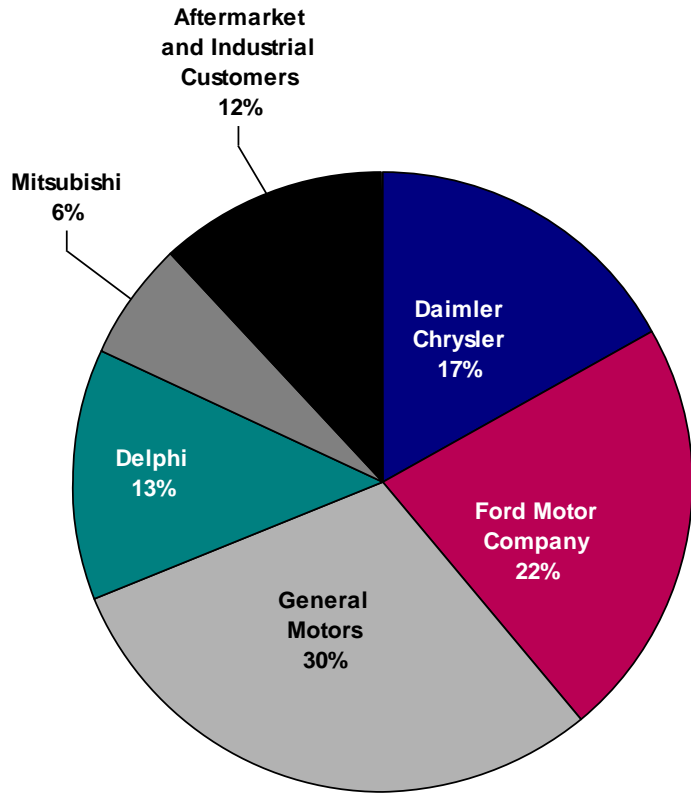

Fiscal Year 2001
Net Sales = \$203 million

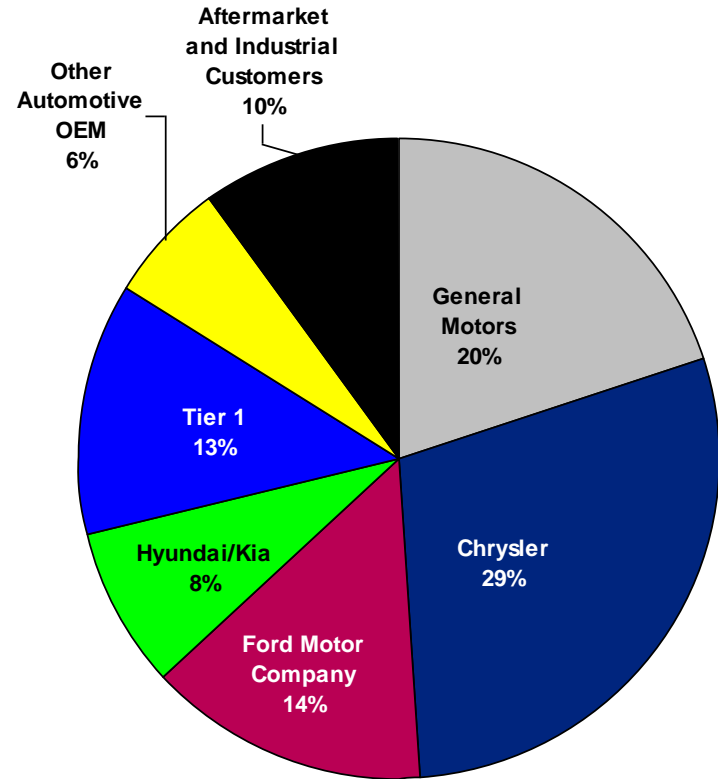

Fiscal Year 2016
Net Sales = \$401 million

NOTE: Page 58 in the 2016 Annual Report

Traditional Product: **Vehicle Lockset**



Sales (in millions of \$)

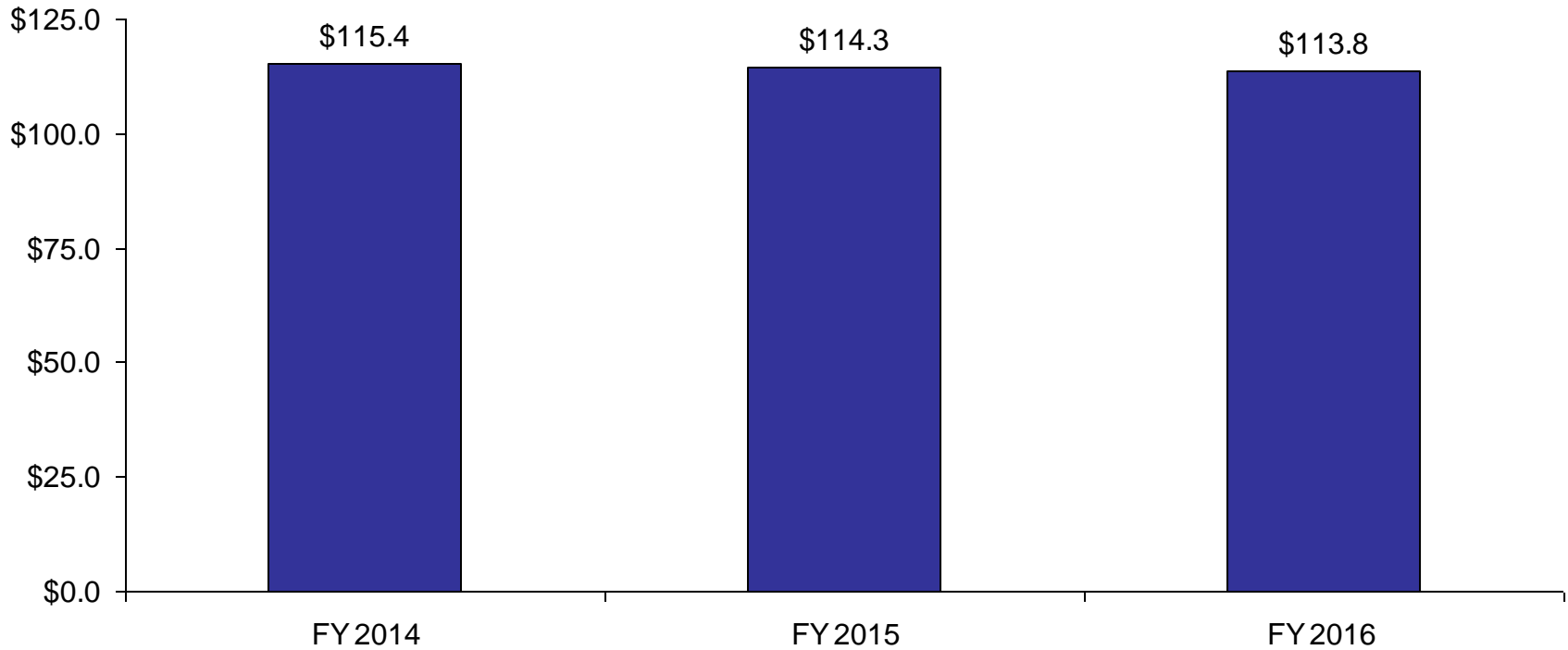

Fiscal Year Ending June

Sales (in millions of \$)

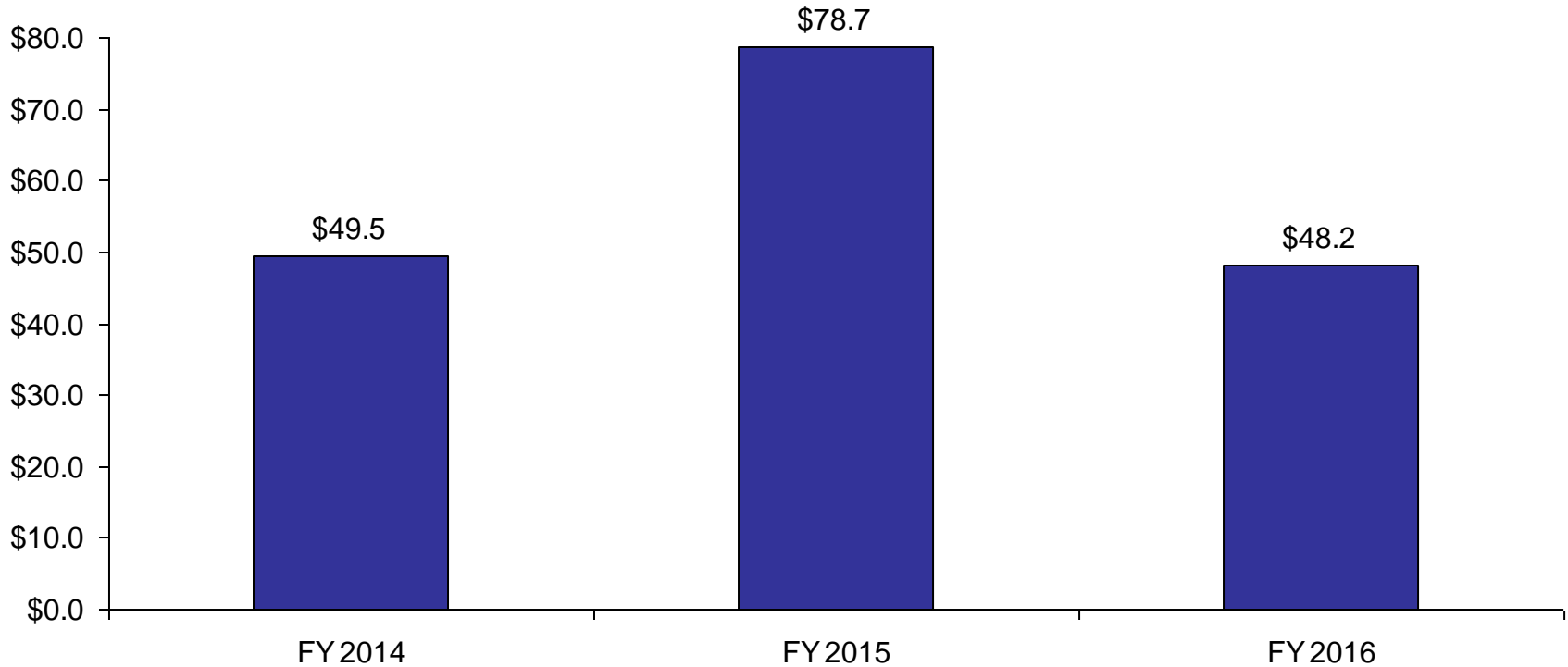

Fiscal Year Ending June

Ignition Lock Housings Primarily Tier II Business



Electronic Steering Column Lock (ESCL)



Sales
(in millions of \$)

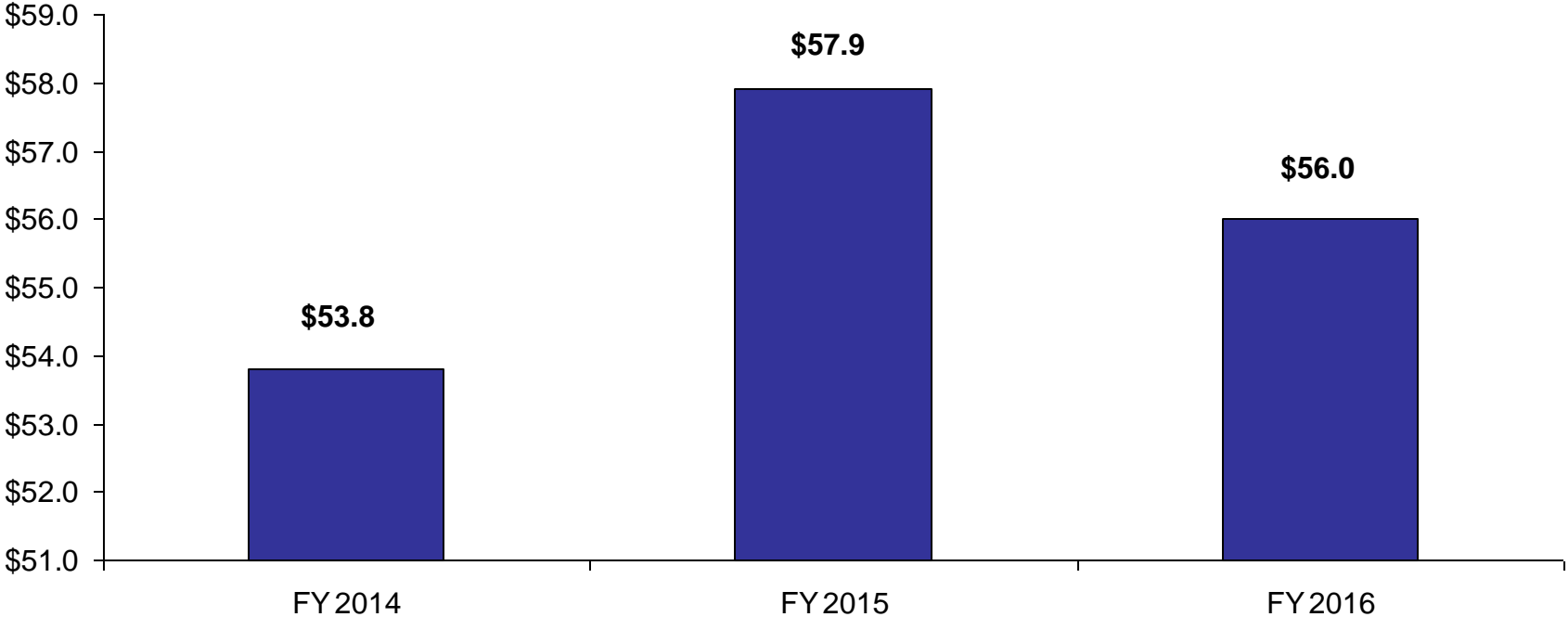

Fiscal Year Ending June





Seat Back Latches



Rear Compartment Latch

2 Versions – power release, or
power release and cinching

Mini-Direct Drive Decklid Latch

- Compact Power & Manual Release Latch

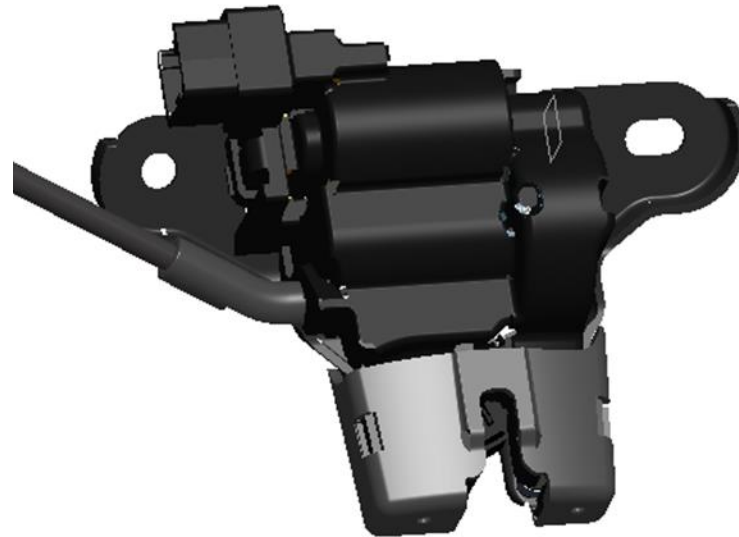

Sales
(in millions of \$)

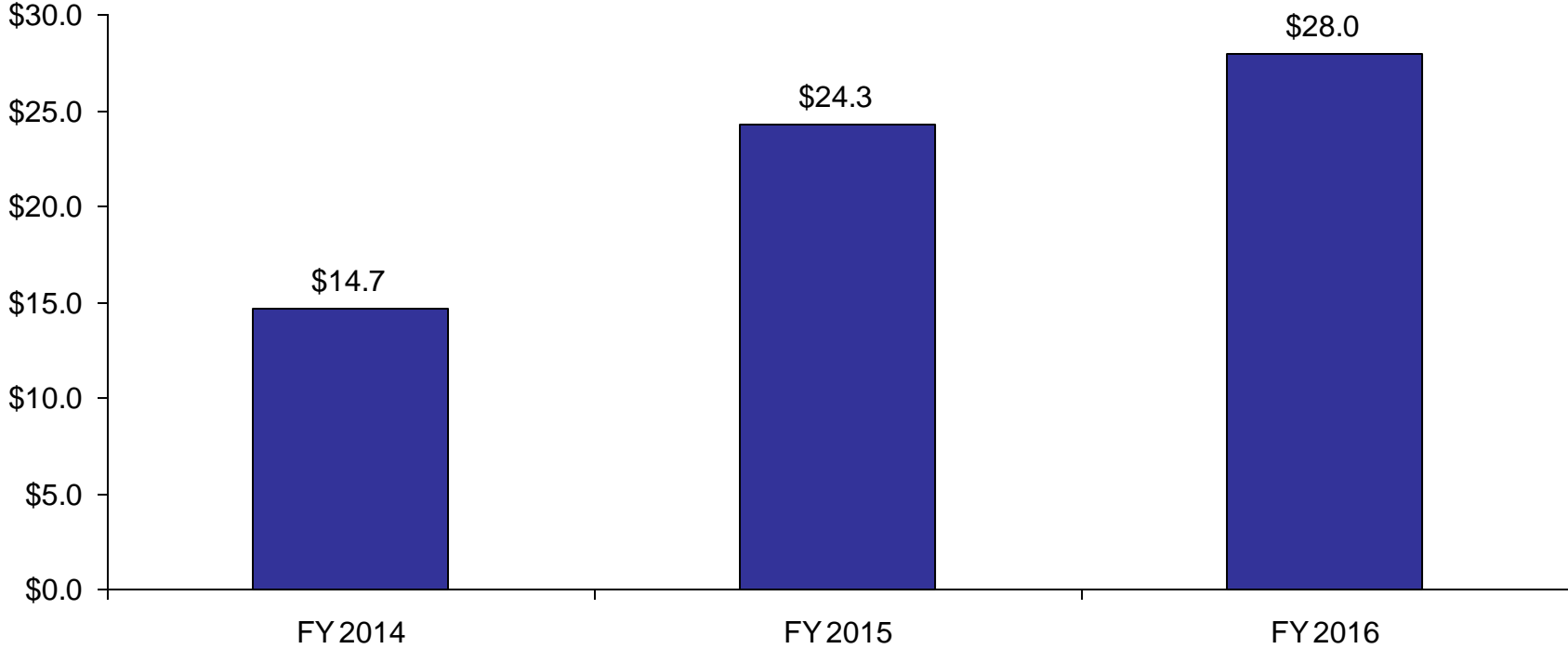

Fiscal Year Ending June



Power Access Business Overview

- Business Acquired November 2008
- Global Customer Base
- Power Sliding Door (PSD)
- Power Liftgate (PLG)
- Power Deck Lid (PDL)
- Power Tonneau Cover (PTC)
- Power Cinching Latch & Striker
- Touchless Obstacle Detection



Sales
(in millions of \$)

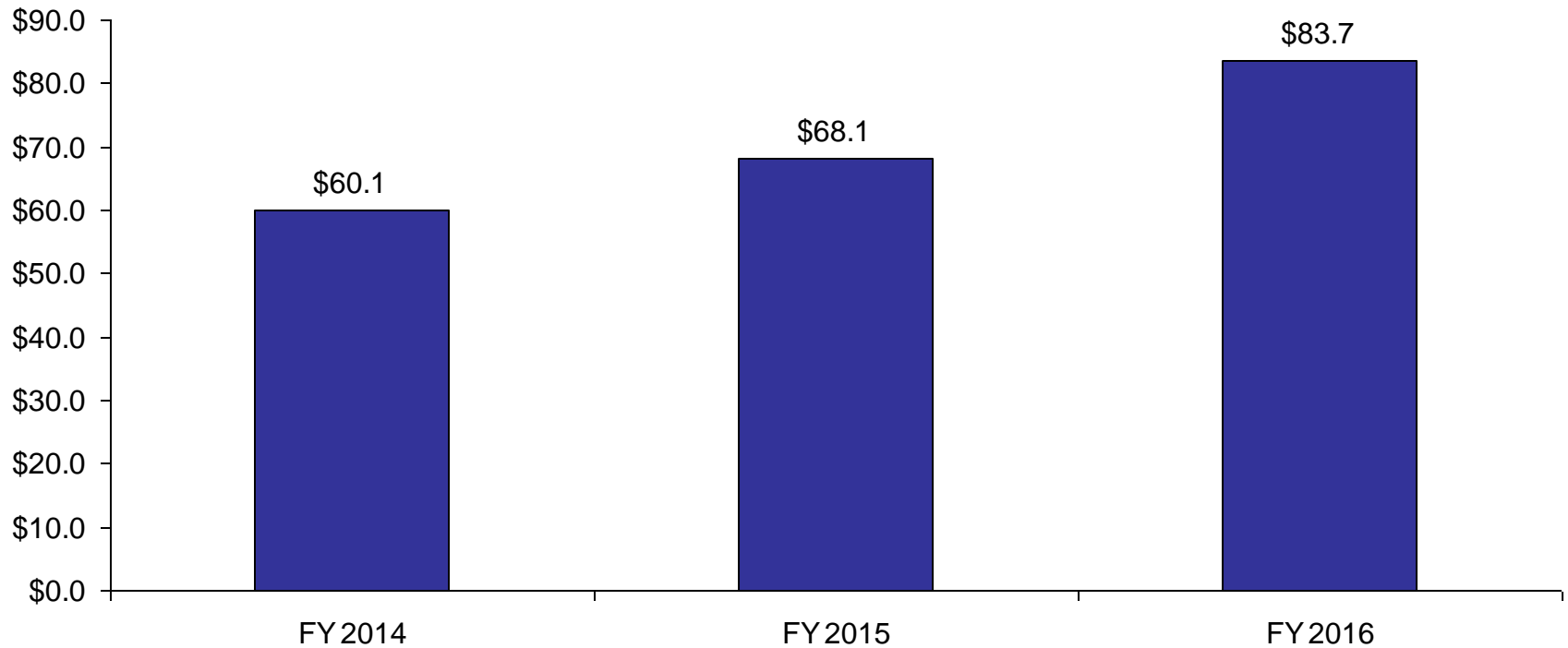

Fiscal Year Ending June

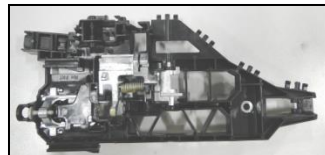
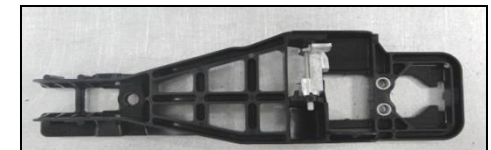
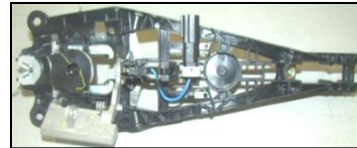
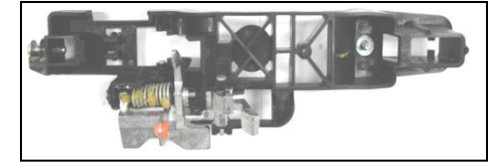
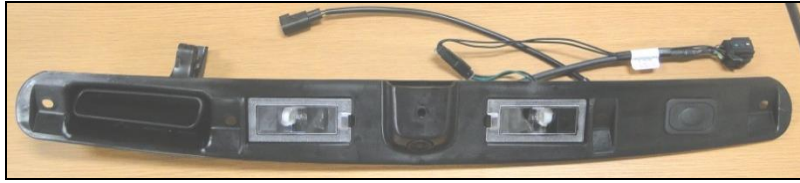

- **Joint Venture with ADAC Automotive. Plastic Injection Molding and Assembly.**
- **Established 2007**
- **Light bar with camera for rear view assist.**
- **Door Chassis and inside handles (with electrical switches and mechanical systems).**

Sales
(in millions of \$)

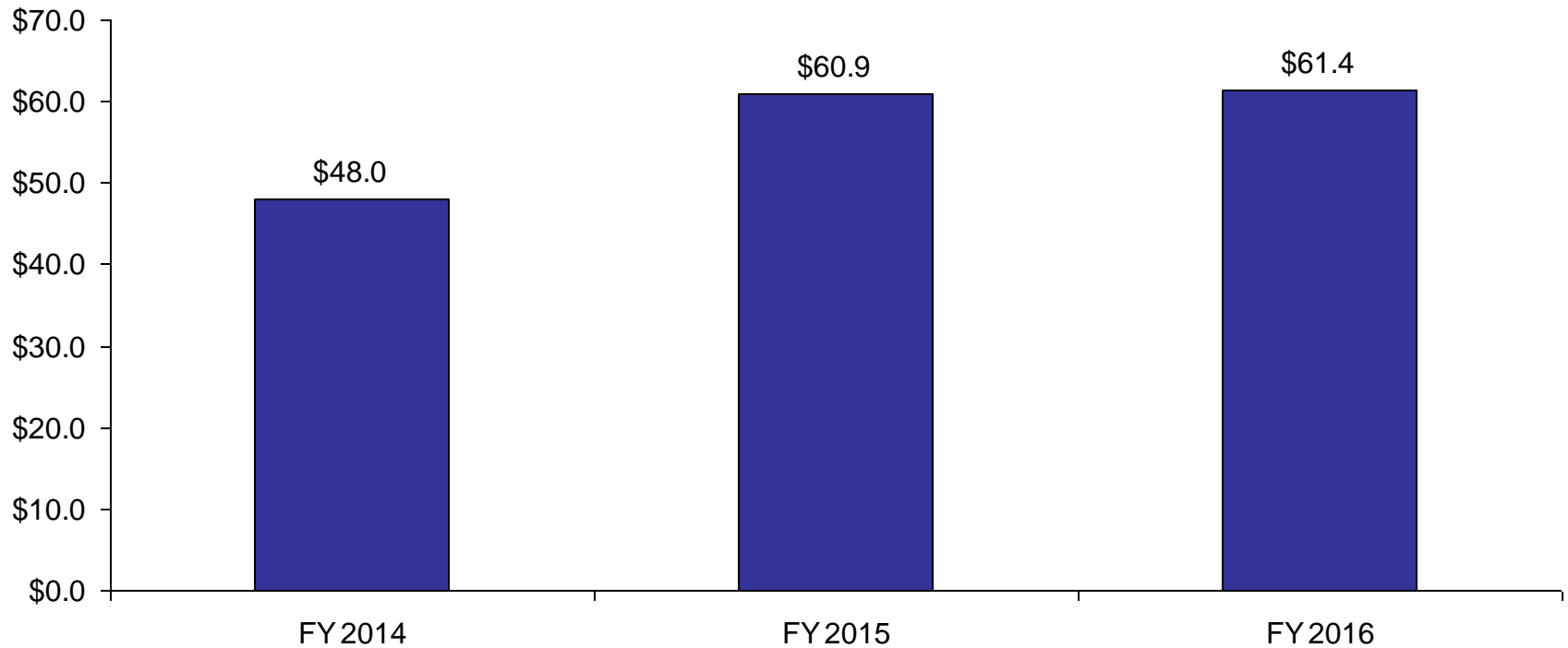

Fiscal Year Ending June

MEXICO'S MANUFACTURING FOOT PRINT

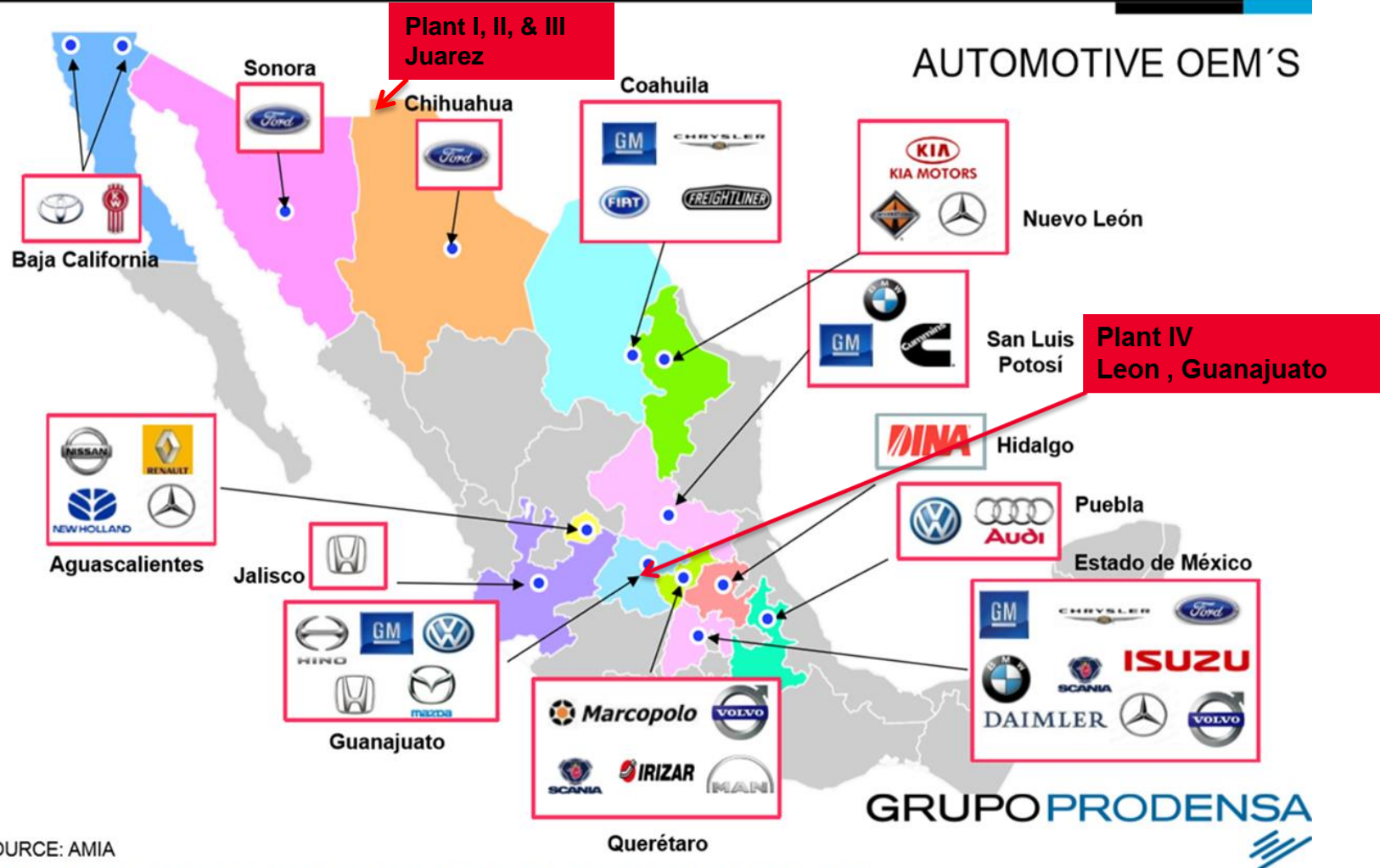

SOURCE: AMIA

- ADAC- STRATTEC Joint Venture: STRATTEC owns 51%
- Adds Paint capability in Mexico Automotive Market that will grow from 3.5 million vehicles in production to over 5 million vehicles during the next 3-5 years
- Have secured Business Awards to support new facility
- Capital Investment for land, building and paint equipment is \$18-20 million
- FY 2017 – STRATTEC’s share of start up costs projected to be less than \$1 million
- FY 2018 – Joint Venture sales will grow from \$60 million today to \$120 million
 - Positive impact on Earnings and should recover start up costs in first year of operation

NEW Plant- Leon, Mexico



Status as of November 2016





Vehicle **A**ccess **S**ystems **T**echnology



- **Strategic partnership:**
 - STRATTEC – Milwaukee, Wisconsin
 - WITTE – Velbert, Germany
 - ADAC – Grand Rapids, Michigan
- **Jointly own 33 1/3 %:**
 - VAST China – Manufacturing & Engineering
 - VAST Brazil - Manufacturing
 - VAST Japan – Sales
 - VAST Korea – Sales & Engineering
- **Growth opportunity:**
 - India with 50% ownership in Minda VAST Access Systems (MVAS)
-  is the brand we are using to grow our global business and protect our home markets

STRATTEC Legal Ownership Structure including VAST:

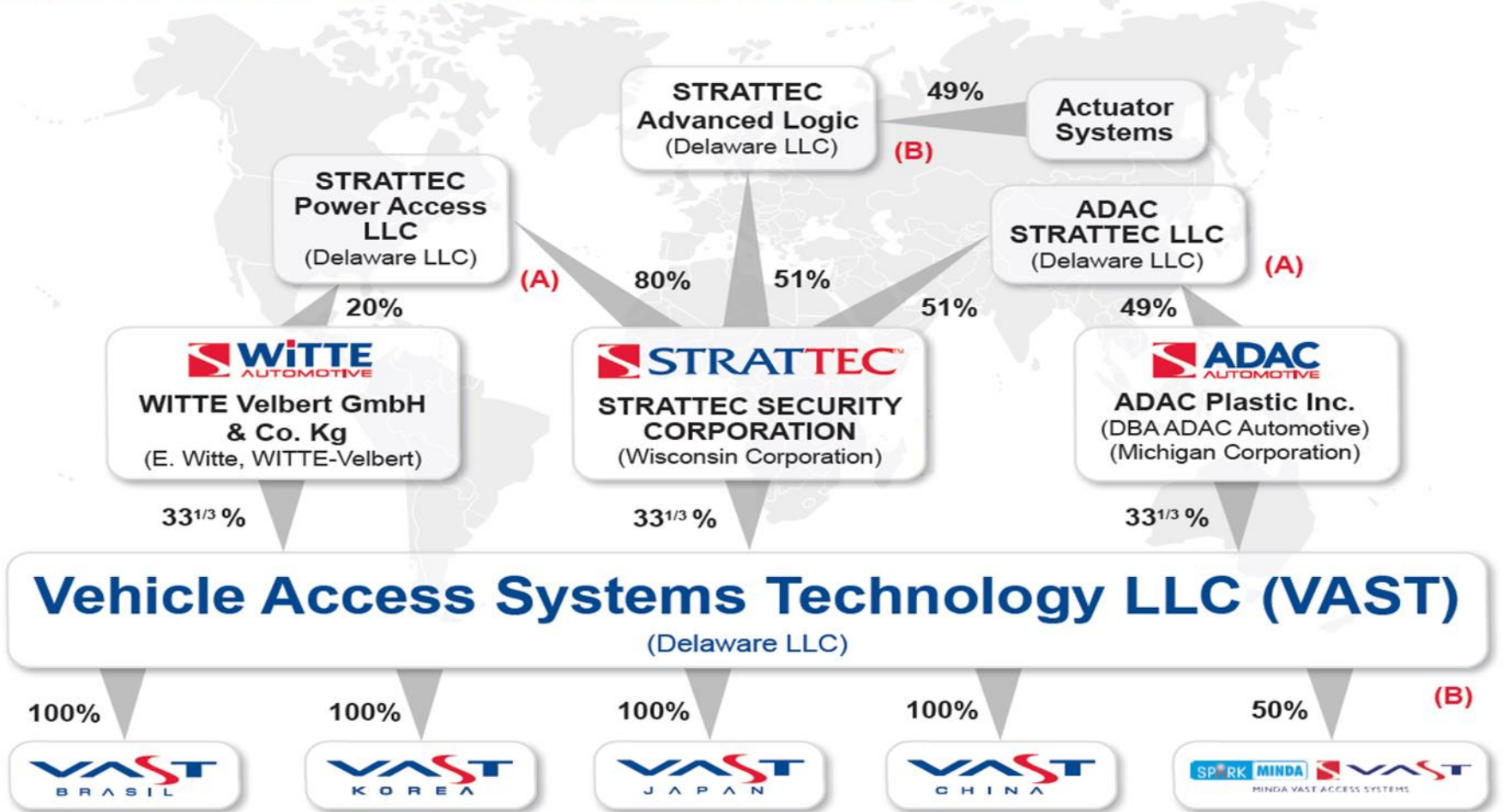

(A) STRATTEC Entities consolidated with a non-controlling interest.

(B) Entities recorded by STRATTEC on the equity method of accounting via "Equity Earnings (Loss)"

- \$1.6 billion + sales (Unconsolidated)
- 16 Manufacturing sites
- 13 Engineering Centers
- Employment over 9,500

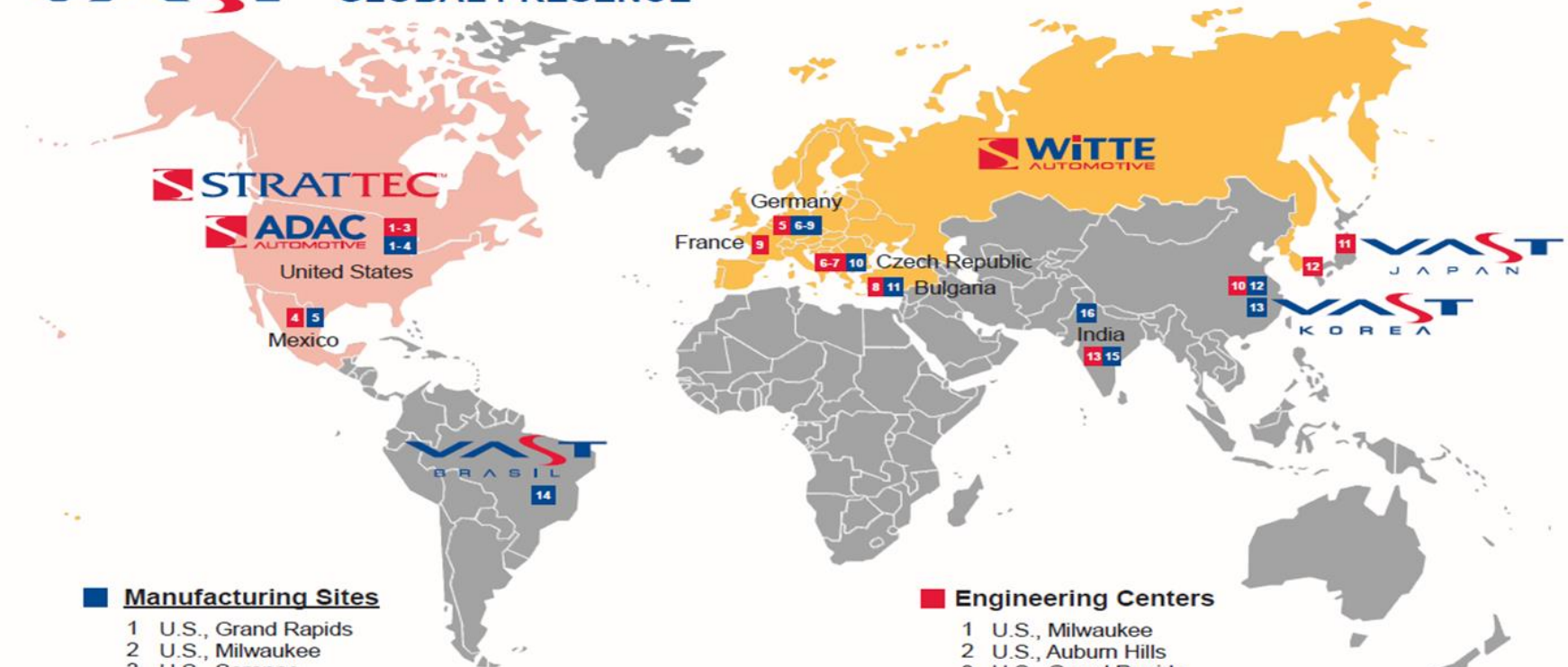
GLOBAL PRESENCE

■ Manufacturing Sites

- 1 U.S., Grand Rapids
- 2 U.S., Milwaukee
- 3 U.S., Saranac
- 4 U.S., Muskegon (3)
- 5 Mexico, Juarez (3)
- 6 Germany, Velbert
- 7 Germany, Wuelfrath
- 8 Germany, Bitburg
- 9 Germany, Stromberg
- 10 Czech Republic, Nejdek
- 11 Bulgaria, Ruse
- 12 China, Taicang
- 13 China, Fuzhou
- 14 Brazil, Sao Paulo
- 15 India, Pune
- 16 India, Delhi

- STRATTEC / ADAC Region
- WITTE Region
- VAST Region

■ Engineering Centers

- 1 U.S., Milwaukee
- 2 U.S., Auburn Hills
- 3 U.S., Grand Rapids
- 4 Mexico, Juarez
- 5 Germany, Velbert
- 6 Czech Republic, Nejdek
- 7 Czech Republic, Pilzen
- 8 Bulgaria, Ruse
- 9 France, Paris
- 10 China, Taicang
- 11 Japan, Tokyo
- 12 South Korea, Anyang
- 13 India, Pune

Passenger Vehicle Manufacturers



Commercial Vehicle Manufacturers



System Suppliers



In Millions
Of US Dollars

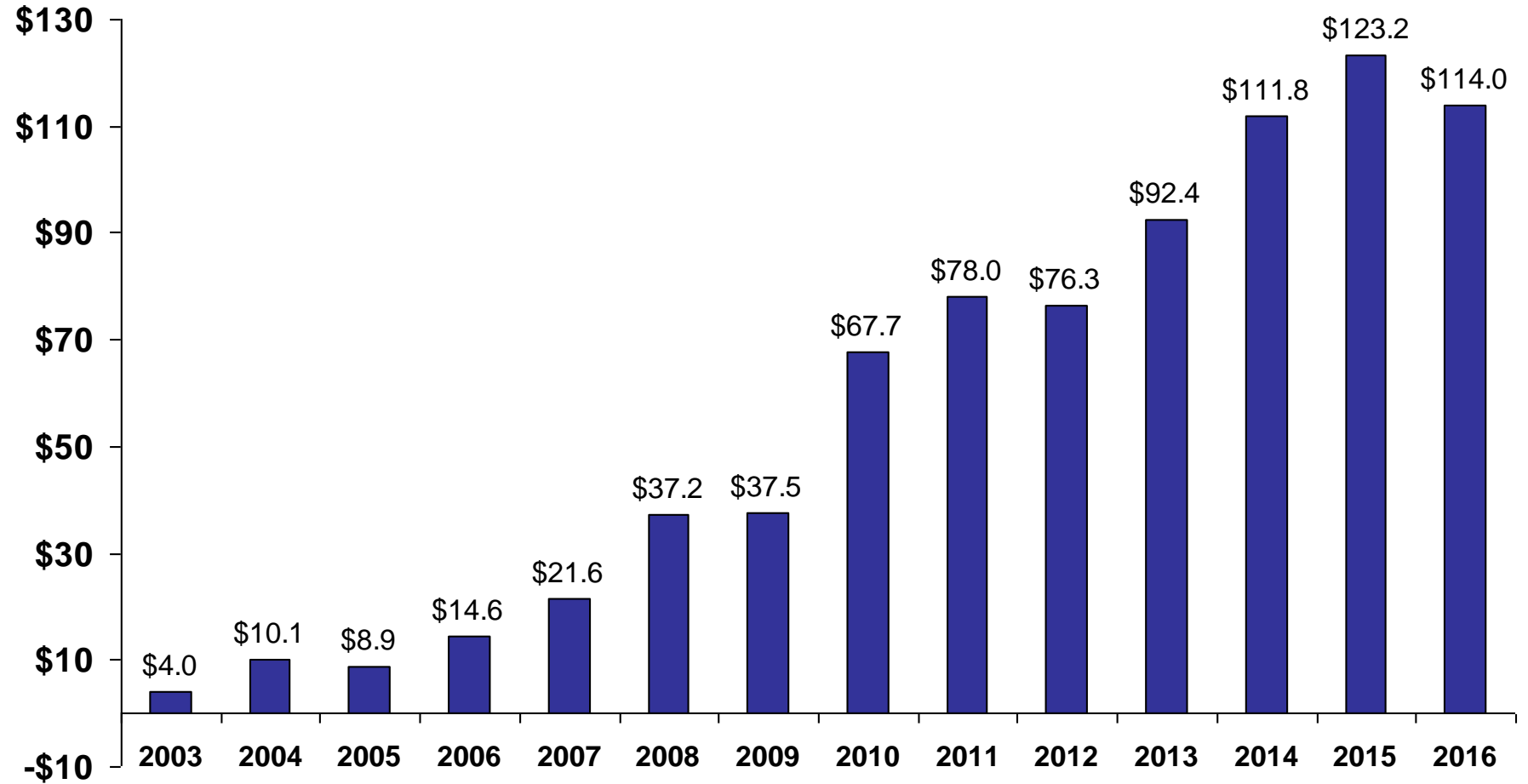

Product Strategy

- Latches (Existing)
- Locks and Keys (Existing)
- Door Handles (Existing)
- Keyless Engine Start Products (Existing)
- Power Access Products (New)
- Driver Control Electronic Steering Column Locks (ESCL)(New)

150,000 sq. ft. manufacturing facility in Taicang, China.



- Expanded Global Footprint to include India
- Record Sales and Profits for Fiscal Year 2015
- Fully Funded Pension as of June 30, 2016
- Added to Russell 2000 in July 2014
- Ford Rotunda Supplier of the Year in 2015 and 2014, Chrysler Supplier of the Year in Electronics 2013 and VAST Partners awarded Supplier of Year for General Motors and Volkswagen in 2013

- STRATTEC is a very different business than it was 15 years ago
 - Broader product line; less reliance on one product
 - Larger customer base and global footprint
 - Capitalizing on both new product opportunities and utilization of existing assets through STRATTEC Component Solutions to deliver growth

- Focus on key financial performance metrics to:
 - Improve gross profit margins
 - Reduce selling, engineering and administrative costs
 - Maintain strong balance sheet and cash flow for strategic investments

STRATTEC's long-term strategy is focused on maximizing long-term shareholder value by driving profitable growth. Our management believes productivity improvements and cost reductions are critical to our competitiveness, while enhancing the value we deliver to our customers. In order to accomplish this, we have been pursuing, and continue to pursue, the following objectives as summarized below:

- Streamline and standardize processes to increase productivity and improve quality of our products
- Maintain a disciplined and flexible cost structure to leverage scale and optimize assets utilization and procurement
- Maintain our strong financial position by deploying capital spending targeted for growth and productivity improvement
- Leverage the “VAST Brand” with customer relationships to generate organic growth from global programs
- Offer our customers innovative products and cost savings solutions to meet their changing demands
- Explore and execute targeted mergers and acquisitions with a disciplined due diligence approach and critical financial analysis to drive shareholder value

We use several key performance indicators to gauge progress toward achieving these objectives. These indicators include net sales growth, operating margin improvement, return on capital employed and cash flow from operations.



Questions?